



# Yealink BH76 Bluetooth Wireless Headset User Guide

[Home](#) » [Yealink](#) » Yealink BH76 Bluetooth Wireless Headset User Guide

Yealink BH76 Bluetooth Wireless Headset User Guide



## Contents [ [hide](#) ]

- 1 Package List
- 2 Power on/off and Pairing
- 3 Call Control
- 4 Music Control
- 5 Customers Key
- 6 Charging
- 7 Replace Ear Cushions
- 8 How to Find Label
- 9 Software Management
- 10 Notes for BHC76 (optional)
- 11 Safety Guide for BHC76 (optional)
- 12 Regulatory Notices
- 13 Warranty
- 14 Safety Instructions
- 15 Troubleshooting
- 16 FCC Statement
- 17 Contact Information
- 18 About Yealink
- 19 Documents / Resources
- 20 Related Posts

## Package List

- BH76



- USB 2.0 Cable (USB-A to USB-C)

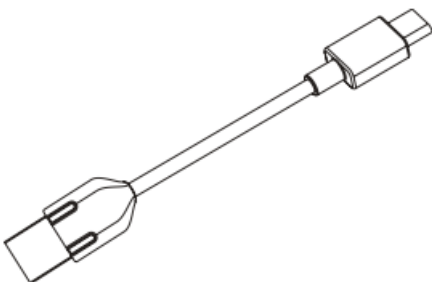

- Zipper Bag



- BT51-A (BT51-C) Dongle

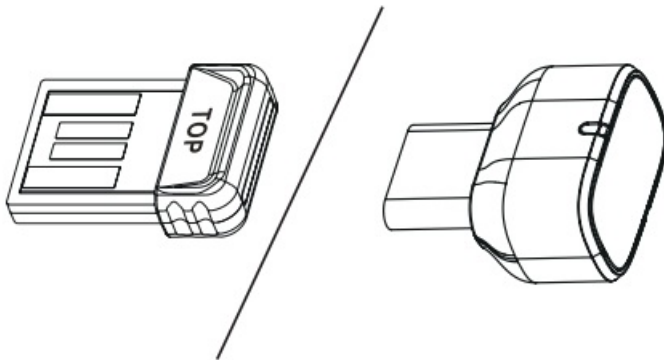

- Quick Start Guide

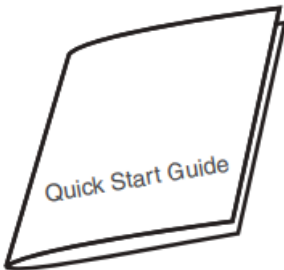

- Optional

- BHC76 Wireless Charging Stand

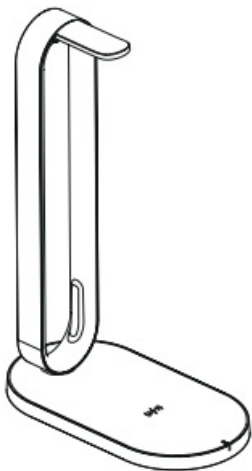

- Power Adapter

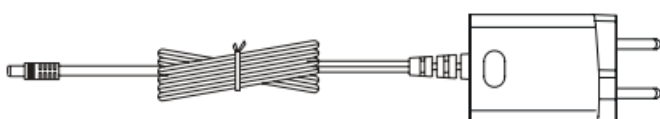

**Note:** We recommend that you use the included accessories, and other accessories may have compatibility issues that prevent them from working properly.

## Power on/off and Paring

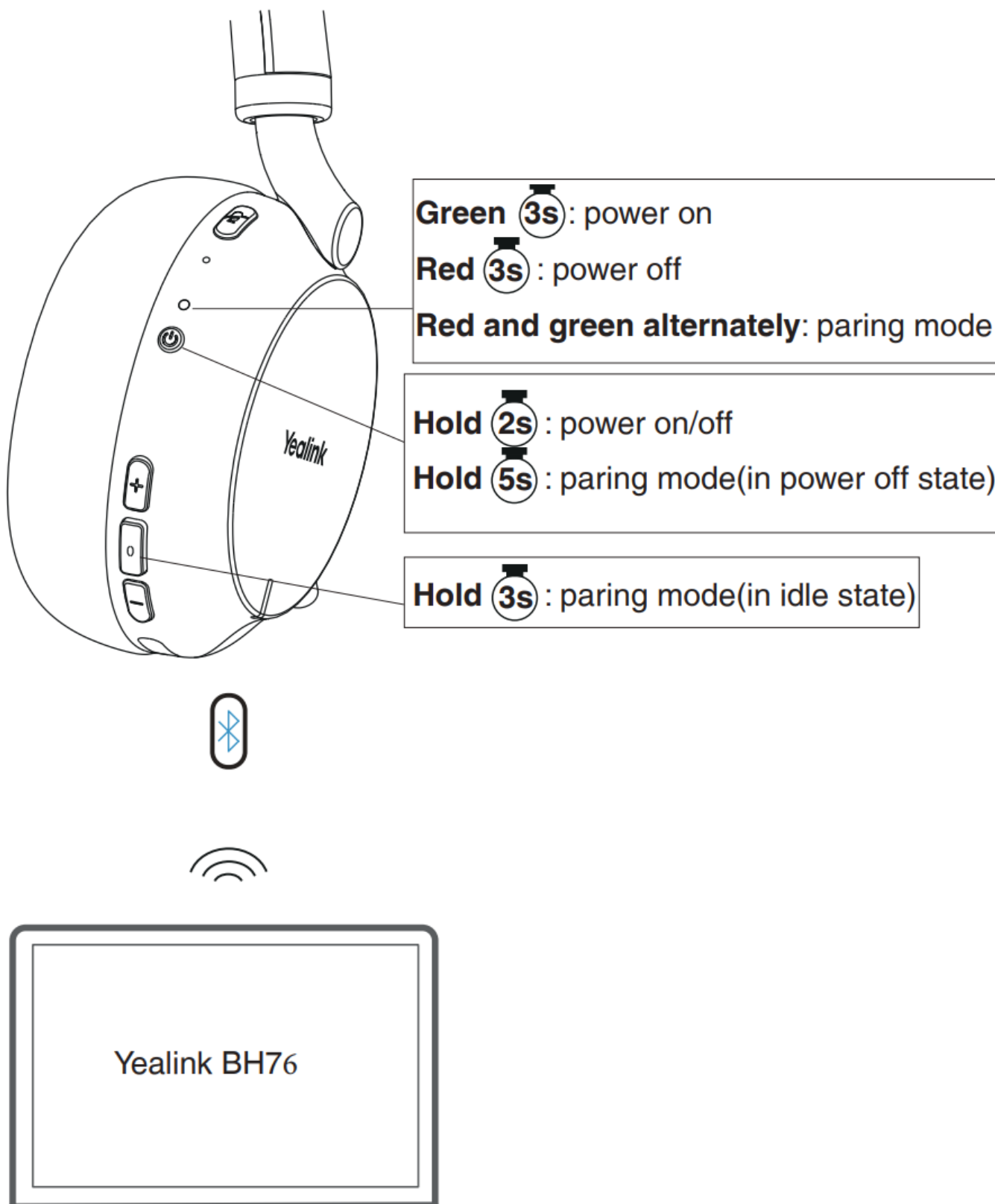

When the headset enters pairing mode, turn on the Bluetooth feature on your device and select Yealink BH76 from the device list to connect to the headset.

**Note:** If your desk phone/PC does not has built-in Bluetooth, you need to use the BT dongle.

## Call Control

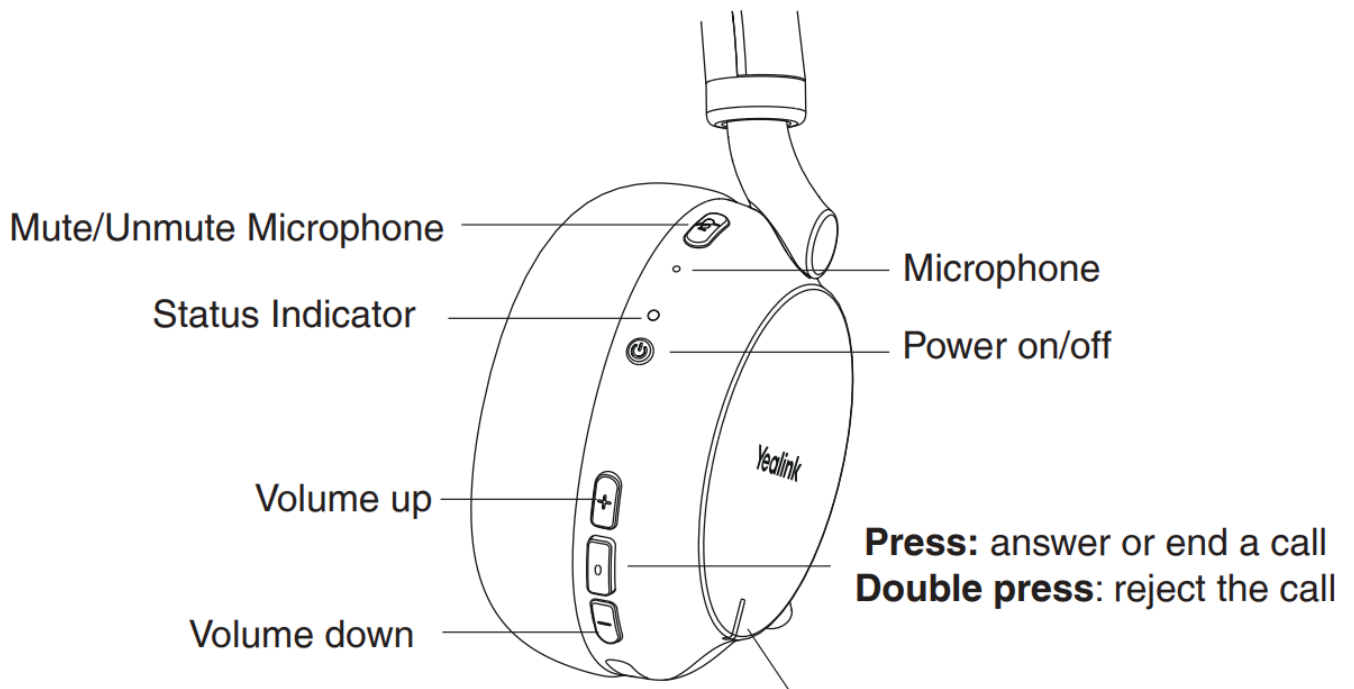

- **Busylight:**
- **Flashing red:** receive an incoming call
- **Solid red:** In a call
- **Flashing purple:** try to connect with Teams(for Teams Edition)
- **Solid purple:** connect to Teams(for Teams Edition)

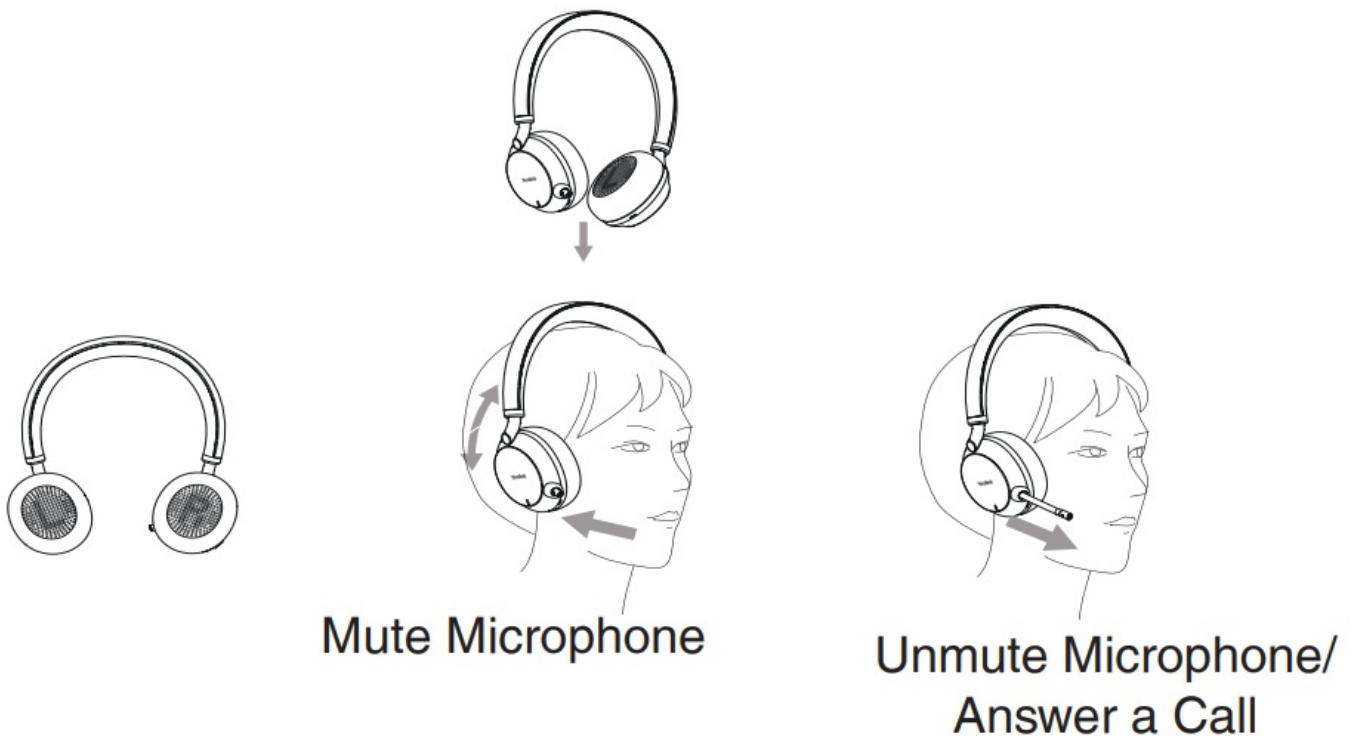

## Music Control

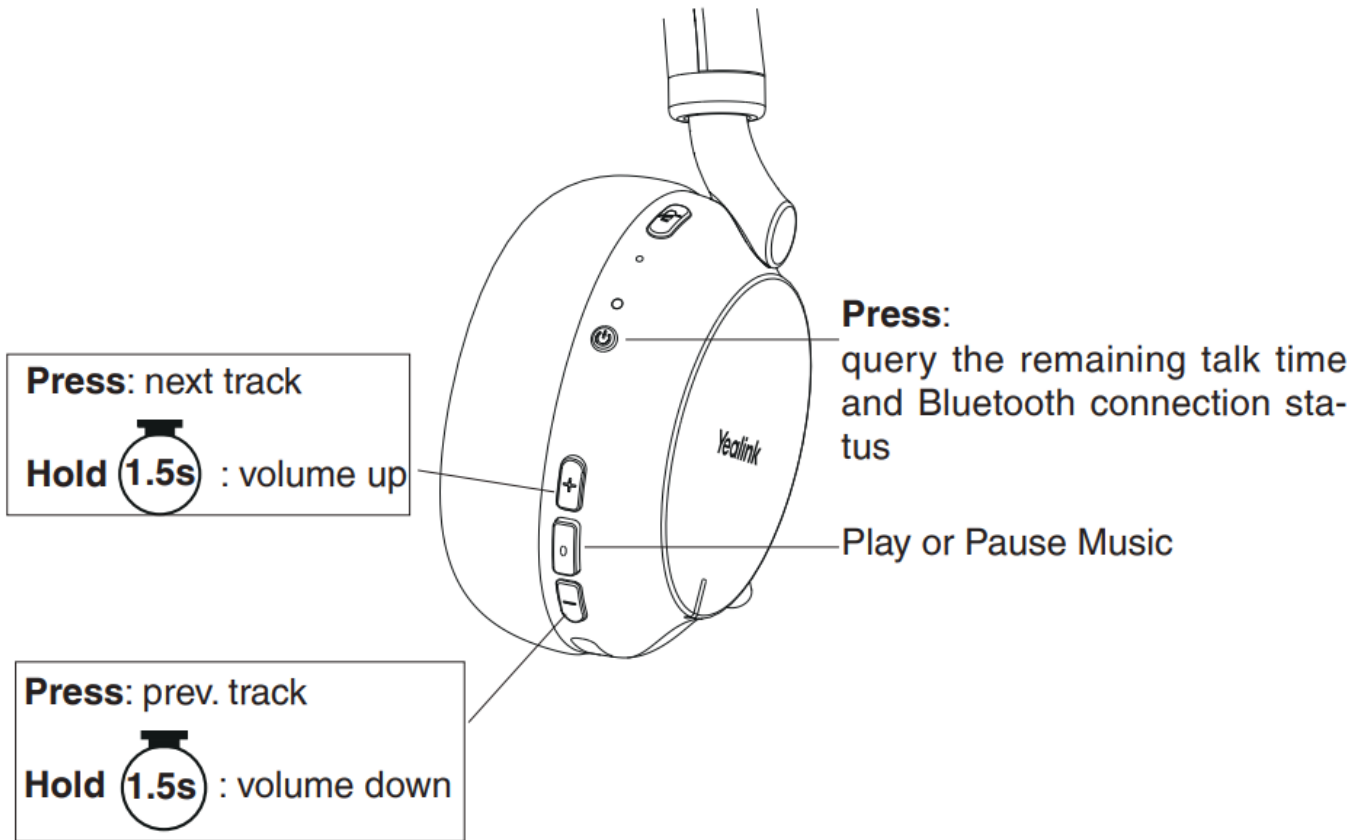

### Customers Key

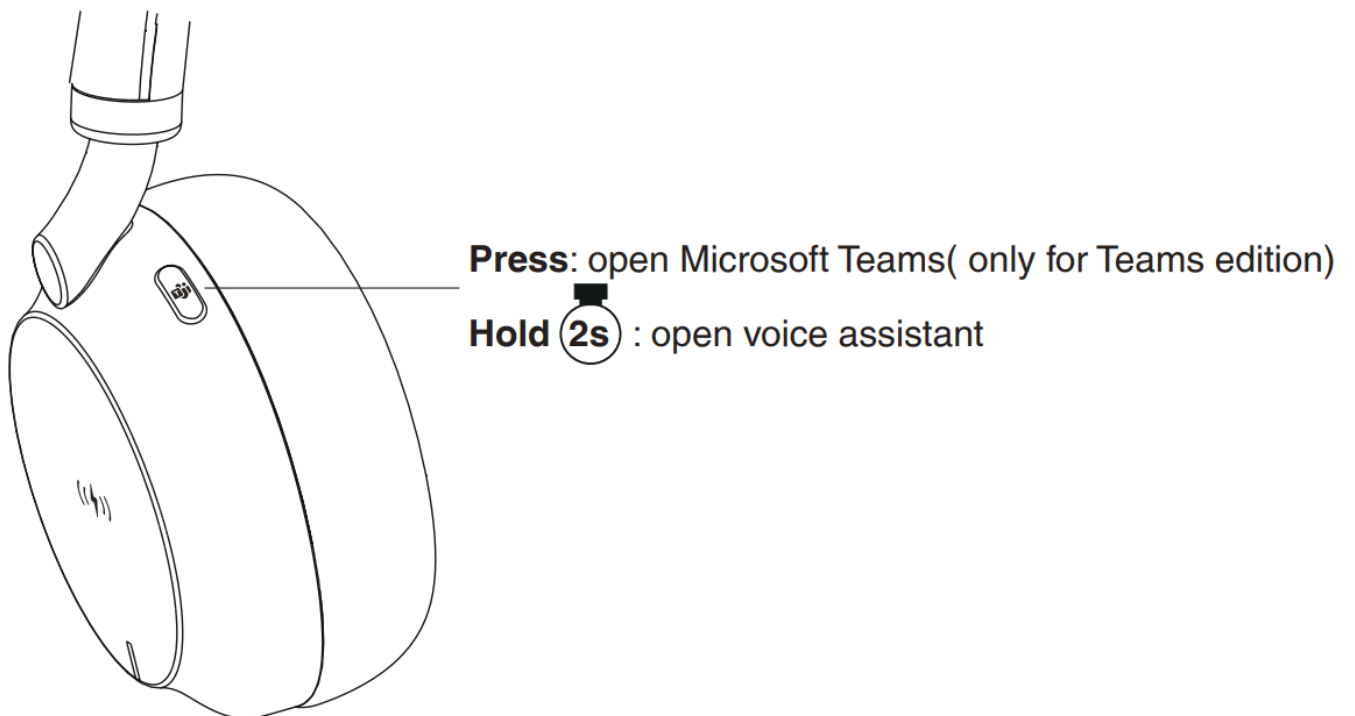

### Charging



- USB Charging

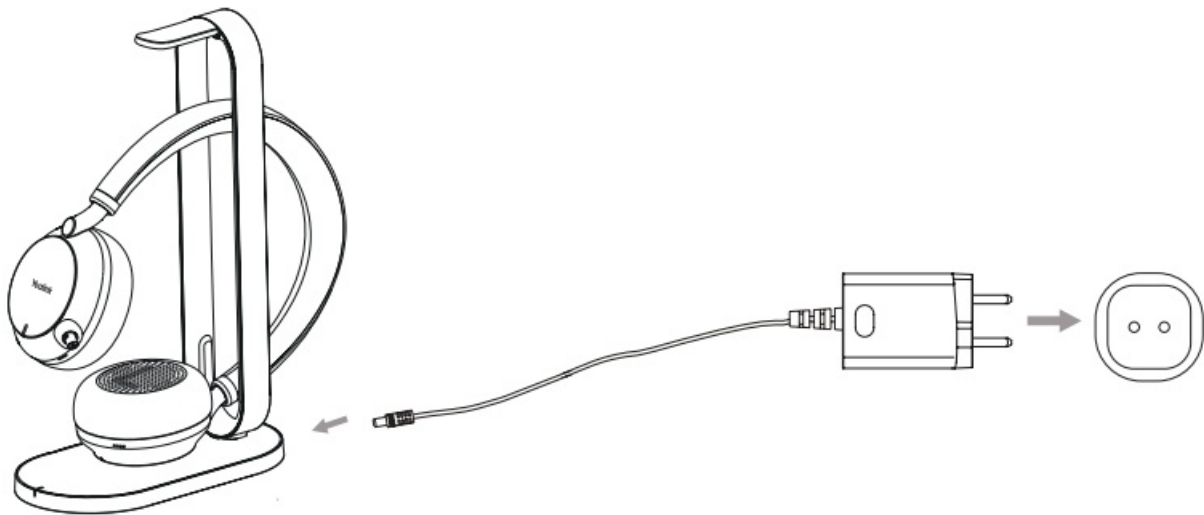

- Wireless Charging (optional)



**Note:**

- Please align the  on the headset with the  on the wireless charging stand if you use BHC76 to charge.
- When the status indicator is solid red, the headset is charging, when the it is solid green that means the headset is fully charged.

**Replace Ear Cushions**

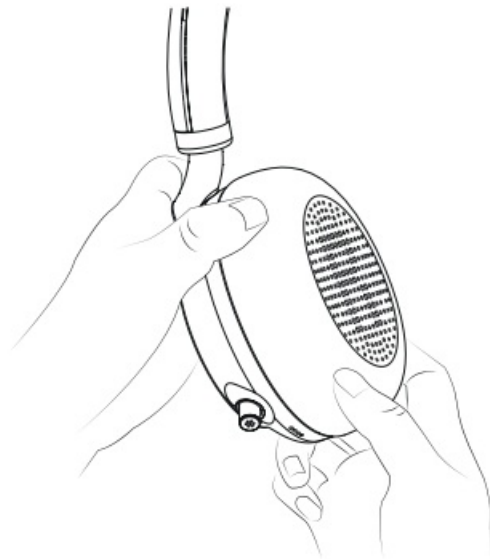
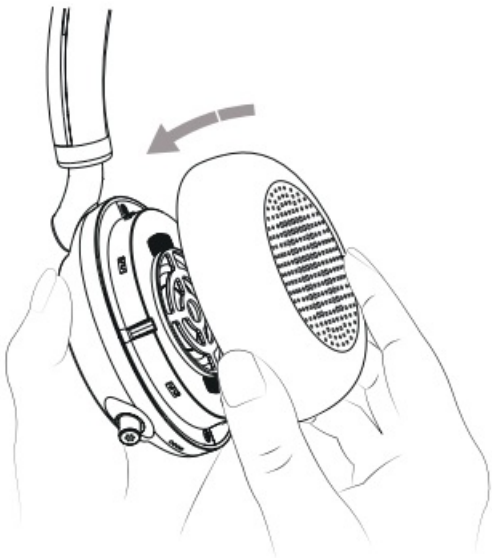
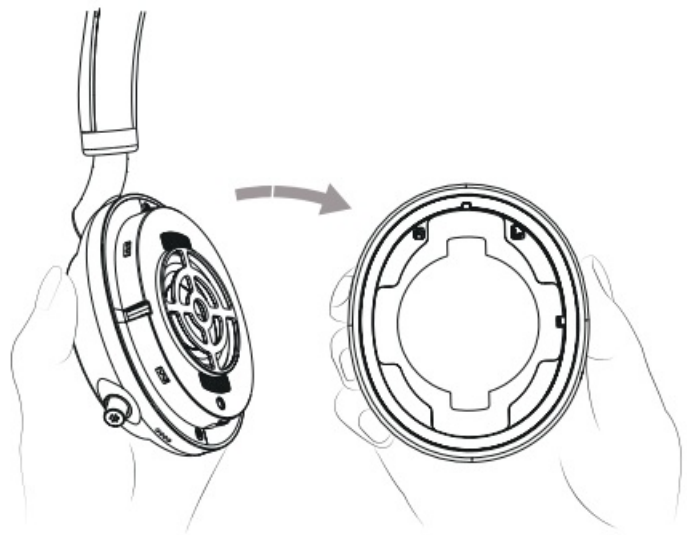
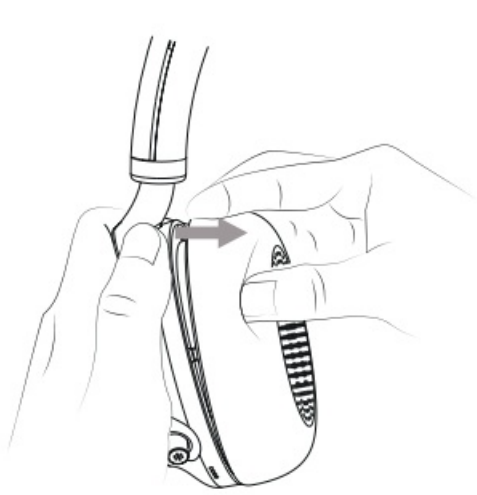

### How to Find Label

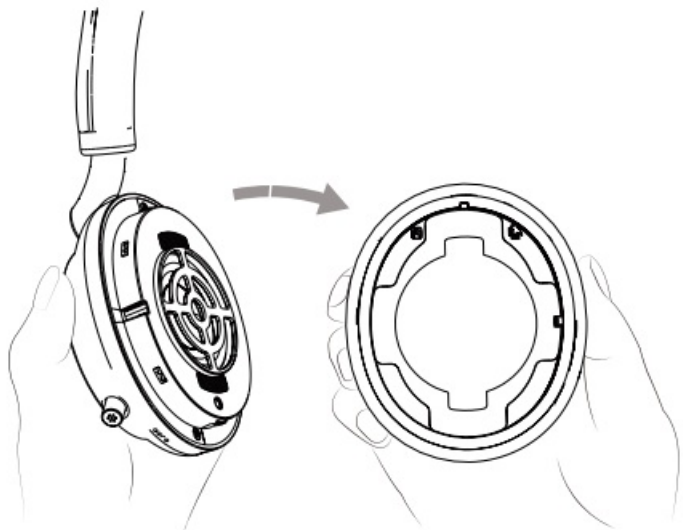
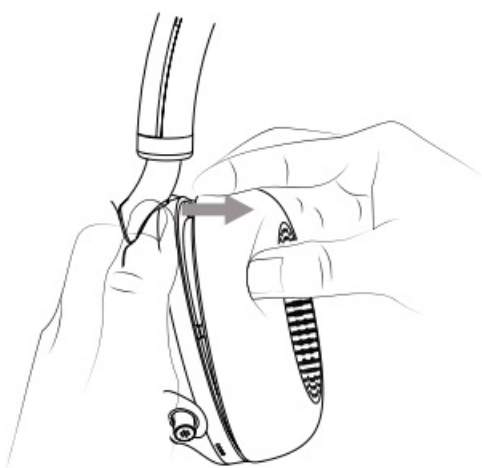



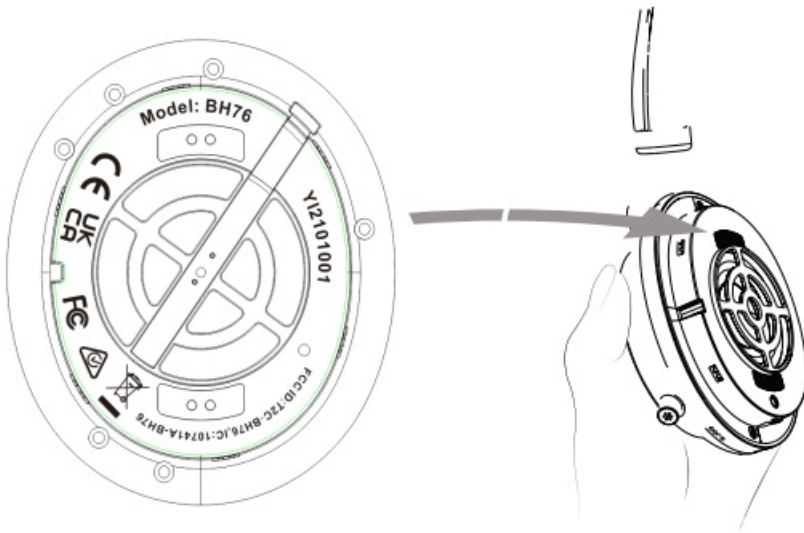

## Software Management

### Yealink USB Connect (PC)

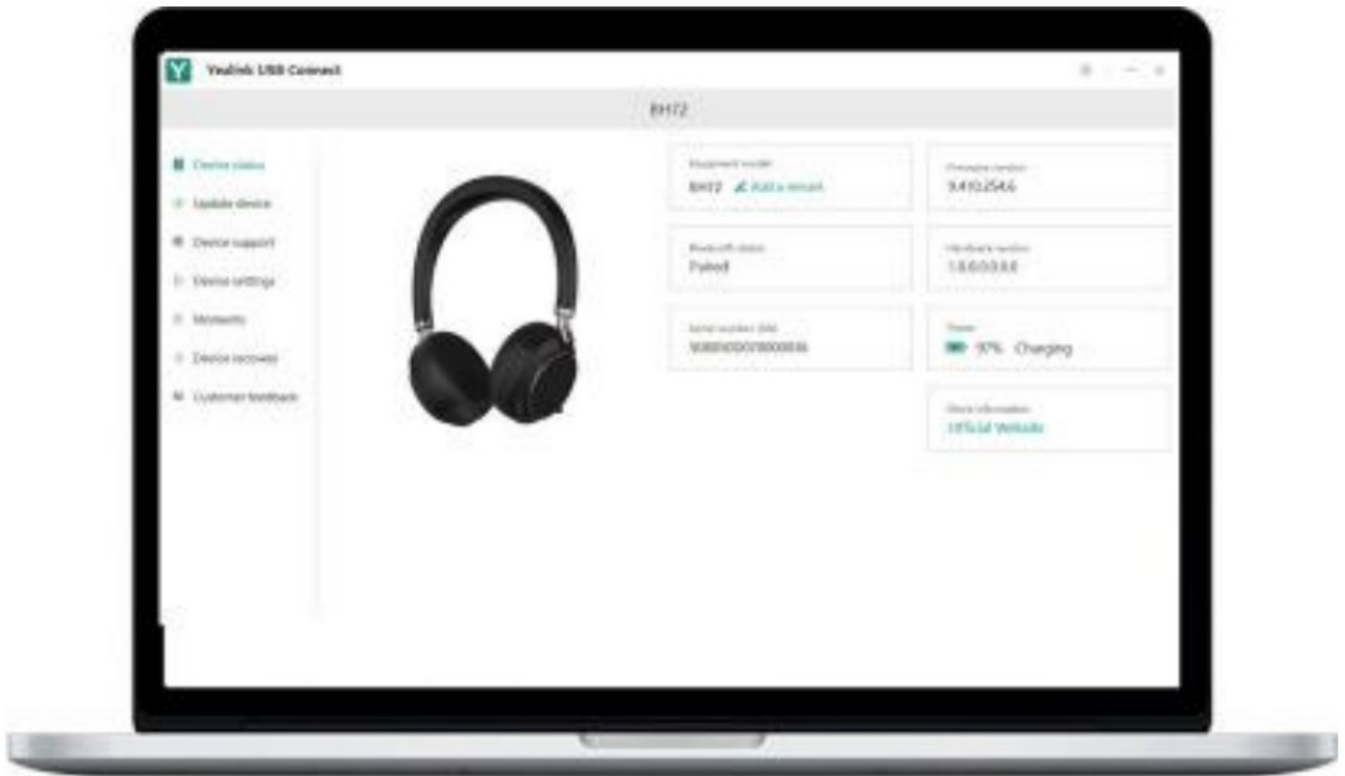

Download it from the Yealink website <https://www.yealink.com/product/yuc>.

**Note:** It needs to be used with Yealink USB Connect of version 0.33.x.x or higher.

### Yealink Connect APP (Mobile)





## Notes for BHC76 (optional)

1. In order to get a more efficient charging experience, please use the provided power adapter.
2. Do not put metal debris or magnetic cards on the charging board to avoid abnormalities or damage to the charger.
3. In order to get a more efficient charging experience, please do not charge too far away from the charging iron.
4. If the receiving coil or the transmitting board is overheated and the charging stops (the charging indicator light keeps flashing), please remove the charging product, wait for it to cool down, and try charging again.
5. The indicator light keeps flashing, there are three possible situations:
  - Indicate that the position is not properly placed, and re-place the charging object. After the position is calibrated, until the indicator light is always on, the battery will be charged normally.
  - To ensure a certain degree of safety, the product has an overheating alarm. After the mobile phone or the charging object cools down, it will automatically eliminate the flicker and enter the normal charging state.
  - Put metal debris or magnetic card on the charging board, and remove the metal object or magnetic card.
6. After the device is fully charged, the indicator light will flicker about 15 seconds apart. You can check the charging device to confirm whether it is fully charged.

## Safety Guide for BHC76 (optional)

1. Do not disassemble this product by yourself or throw it into fire or water to avoid short circuit leakage or damage to the product.
2. Please do not use this product in high temperature, humidity or corrosive environment, to avoid damage to the circuit and lead to failure to charge or other failures.
3. Do not expose the product to corrosive liquids, otherwise it will cause serious damage.
4. Do not disassemble or modify this product for any reason to avoid secondary failure and burnout.
5. Do not place the product below  $-10^{\circ}\text{C}$  or above  $60^{\circ}\text{C}$ .
6. Do not knock, throw or vibrate this product strongly. Rough methods will damage the internal circuit board structure.

## Regulatory Notices

### Operating Ambient Temperatures

- Operating temperature:  $+32$  to  $104^{\circ}\text{F}$  ( $0$  to  $40^{\circ}\text{C}$ )
- Relative humidity: 5% to 90%, noncondensing

- Storage temperature: -22 to +160°F (-30 to +70°C)

## Warranty

Our product warranty is limited only to the unit itself, when used normally in accordance with the operating instructions and the system environment. We are not liable for damage or loss resulting from the use of this product, or for any claim from a third party. We are not liable for problems with Yealink device arising from the use of this product; we are not liable for financial damages, lost profits, claims from third parties, etc., arising from the use of this product.

## Explanation of the symbols

- DC symbol

 is the DC voltage symbol.

- WEEE Warning symbol



To avoid the potential effects on the environment and human health as a result of the presence of hazardous substances in electrical and electronic equipment, end users of electrical and electronic equipment should understand the meaning of the crossed-out wheeled bin symbol. Do not dispose of WEEE as unsorted municipal waste and have to collect such WEEE separately.

## Restriction of Hazardous Substances Directive (RoHS)

This device complies with the requirements of the EU RoHS Directive. Statements of compliance can be obtained by contacting [support@yealink.com](mailto:support@yealink.com).

## Safety Instructions

Save these instructions. Read these safety instructions before use!



### General Requirements

- Before you install and use the device, read the safety instructions carefully and observe the situation during operation.
- During the process of storage, transportation, and operation, please always keep the device dry and clean, avoid collision and crash.
- Please attempt not to dismantle the device by yourself. In case of any discrepancy, please contact the appointed maintenance center for repair.
- Please refer to the relevant laws and statutes while using the device. Legal rights of others should be respected as well.



### Environmental Requirements

- Place the device at a well-ventilated place. Do not expose the device under direct sunlight.
- Keep the device dry and free of dusts.
- Do not place the device on or near any inflammable or fire-vulnerable object, such as rubber-made materials.
- Keep the device away from any heat source or bare fire, such as a candle or an electric heater.



### **Operating Requirements**

- Do not let a child operate the device without guidance.
- Do not let a child play with the device or any accessory in case of accidental swallowing.
- Please use the accessories provided or authorized by the manufacturer only.
- The power supply of the device shall meet the requirements of the input voltage of the device. Please use the provided surge protection power socket only.
- Before plugging or unplugging any cable, make sure that your hands are completely dry.
- Do not spill liquid of any kind on the product or use the equipment near water, for example, near a bathtub, washbowl, kitchen sink, wet basement or near a swimming pool.
- During a thunderstorm, stop using the device and disconnect it from the power supply. Unplug the power plug and the Asymmetric Digital Subscriber Line (ADSL) twisted pair (the radio frequency cable) to avoid lightning strike.
- If the device is left unused for a rather long time, disconnect it from the power supply and unplug the power plug.
- When there is smoke emitted from the device, or some abnormal noise or smell, disconnect the device from the power supply, and unplug the power plug immediately.
- Contact the specified maintenance center for repair.
- Do not insert any object into equipment slots that is not part of the product or auxiliary product.
- Before connecting a cable, connect the grounding cable of the device first. Do not disconnect the grounding cable until you disconnect all other cables.



### **Battery Requirements**

- Do not immerse the battery into water, which could short-circuit and damage the battery.
- Do not expose the battery to an open flame or leave the battery where it could be subjected to extremely high temperatures, which could cause the battery to explode.
- Do power the handset off before removing the battery.
- Do not try to use the battery for the power supply of any device other than this handset.
- Do not open or mutilate the battery, released electrolyte is corrosive and may cause damage to your eyes or skin.
- Use only the rechargeable battery pack delivered with the handset or those rechargeable battery packs expressly recommended by Yealink.
- Defective or exhausted battery should never be disposed of as municipal waste. Return old battery to the battery supplier, a licensed battery dealer or a designated collection facility.



## Cleaning Requirements

- Before cleaning the device, disconnect it from the power supply.
- Use a piece of soft, dry and anti-static cloth to clean the device.
- Keep the power plug clean and dry.

## Troubleshooting

The unit cannot supply power to Yealink device.  
There is a bad connection with the plug.

1. Clean the plug with a dry cloth.
2. Connect it to another wall outlet.

The usage environment is out of operating temperature range.

1. Use in the operating temperature range.

The cable between the unit and the Yealink device is connected incorrectly.

1. Connect the cable correctly.

You cannot connect the cable properly.

1. You may have connected a wrong Yealink device.
2. Use the correct power supply.

Some dust, etc., may be in the port.

1. Clean the port.

Contact your dealer or authorized service facility for any further questions.

## FCC Statement

This device complies with part 15 of the FCC Rules. Operation is subject to the following two conditions: (1) this device may not cause harmful interference, and (2) this device must accept any interference received, including interference that may cause undesired operation.

Any Changes or modifications not expressly approved by the party responsible for compliance could void the user's authority to operate the equipment.

## IMPORTANT NOTE:

**Note:** This equipment has been tested and found to comply with the limits for a Class B digital device, pursuant to part 15 of the FCC Rules. These limits are designed to provide reasonable protection against harmful interference

in a residential installation. This equipment generates, uses and can radiate radio frequency energy and, if not installed and used in accordance with the instructions, may cause harmful interference to radio communications.

However, there is no guarantee that interference will not occur in a particular installation. If this equipment does cause harmful interference to radio or television reception, which can be determined by turning the equipment off and on, the user is encouraged to try to correct the interference by one or more of the following measures:

- Reorient or relocate the receiving antenna.
- Increase the separation between the equipment and receiver.
- Connect the equipment into an outlet on a circuit different from that to which the receiver is connected.
- Consult the dealer or an experienced radio/TV technician for help.

## **IC Statement**

This device complies with Industry Canada's licence-exempt RSSs. Operation is subject to the following two conditions:

1. this device may not cause interference; and
2. this device must accept any interference, including interference that may cause undesired operation of the device. CAN ICES-3(B)

## **Radiation Exposure Statement**

This equipment complies with FCC and IC radiation exposure limits set forth for an uncontrolled environment.

## **Contact Information**

### **YEALINK (XIAMEN ) NETWORK TECHNOLOGY CO., LTD.**

309, 3rd Floor, No.16, Yun Ding North Road, Huli District, Xiamen City, Fujian, P.R.C

### **YEALINK (EUROPE) NETWORK TECHNOLOGY B.V.**

Strawinskylaan 3127, Atrium Building, 8th floor, 1077ZX Amsterdam, The Netherlands

### **YEALINK (USA) NETWORK TECHNOLOGY CO., LTD.**

999 Peachtree Street Suite 2300, Fulton, Atlanta, GA, 30309, USA

Made in China

## **About Yealink**

Yealink (Stock Code: 300628) is a global brand that specializes in video conferencing, voice communications and collaboration solutions with best-in-class quality, innovative technology and user-friendly experience. As one of the best providers in more than 140 countries and regions, Yealink ranks No.1 in the global market share of SIP phone shipments (Global IP Desktop Phone Growth Excellence Leadership Award Report, Frost & Sullivan, 2019).

Copyright

**Copyright © 2021 YEALINK(XIAMEN) NETWORK TECHNOLOGY CO., LTD.**

All rights reserved. No parts of this publication may be reproduced or transmitted in any form or by any means, electronic or mechanical, photocopying, recording, or otherwise, for any purpose, without the express written

permission of Yealink(Xiamen) Network Technology CO., LTD.

### Technical Support

Visit Yealink WIKI (<http://support.yealink.com/>) for firmware downloads, product documents, FAQ, and more. For better service, we sincerely recommend you to use Yealink Ticketing system (<https://ticket.yealink.com>) to submit all your technical issues.



YEALINK(XIAMEN) NETWORK TECHNOLOGY CO.,LTD.

Web: [www.yealink.com](http://www.yealink.com)

# Yealink

### Documents / Resources

|   |   |
|---|---|
|  <p>Yealink<br/>BH76<br/>Bluetooth Headset</p> <p>Quick Start Guide<br/>V1.0</p> | <p><a href="#">Yealink BH76 Bluetooth Wireless Headset</a> [pdf] User Guide<br/>BH76, T2C-BH76, T2CBH76, BH76, Bluetooth Wireless Headset, Bluetooth Headset, Wireless Headset, BH76, Headset</p> |
|---|---|